

## 20V N-Ch Power MOSFET

### Feature

- ◇ High Speed Power Switching, Logic Level
- ◇ Enhanced Avalanche Ruggedness
- ◇ 100% UIS Tested, 100% Rg Tested
- ◇ Lead Free, Halogen Free

$V_{DS}$		20	V
$R_{DS(on),typ}$	$V_{GS}=4.5V$	36	mΩ
$R_{DS(on),typ}$	$V_{GS}=2.5V$	43	mΩ
$R_{DS(on),typ}$	$V_{GS}=1.8V$	58	mΩ
$I_D$ (Silicon Limited)		3.6	A

### Application

- ◇ Hard Switching and High Speed Circuit
- ◇ DC/DC in Telecoms and Industrial

SOT-23

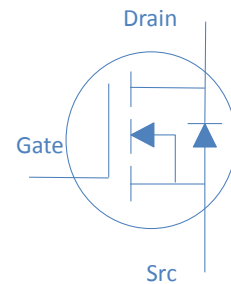
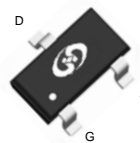

Part Number	Package	Marking
HTJ450N02	SOT23	1Y

### Absolute Maximum Ratings at $T_j=25^\circ\text{C}$ (unless otherwise specified)

Parameter	Symbol	Conditions	Value	Unit
Continuous Drain Current (Silicon Limited)	$I_D$	$T_A=25^\circ\text{C}$	3.6	A
		$T_A=100^\circ\text{C}$	2.9	
Drain to Source Voltage	$V_{DS}$	-	20	V
Gate to Source Voltage	$V_{GS}$	-	$\pm 12$	V
Pulsed Drain Current	$I_{DM}$	-	14	A
Power Dissipation	$P_D$	$T_A=25^\circ\text{C}$	1.04	W
Operating and Storage Temperature	$T_J, T_{stg}$	-	-55 to 150	$^\circ\text{C}$

### Absolute Maximum Ratings

Parameter	Symbol	Max	Unit
Thermal Resistance Junction-Ambient	$R_{\theta JA}$	120	$^\circ\text{C/W}$

**Electrical Characteristics at  $T_J=25^{\circ}\text{C}$  (unless otherwise specified)**
**Static Characteristics**

Parameter	Symbol	Conditions	Value			Unit
			min	typ	max	
Drain to Source Breakdown Voltage	$V_{(BR)DSS}$	$V_{GS}=0V, I_D=250\mu A$	20	-	-	V
Gate Threshold Voltage	$V_{GS(th)}$	$V_{GS}=V_{DS}, I_D=250\mu A$	0.40	0.75	1.2	
Zero Gate Voltage Drain Current	$I_{DSS}$	$V_{GS}=0V, V_{DS}=16V, T_J=25^{\circ}\text{C}$	-	-	1	$\mu A$
		$V_{GS}=0V, V_{DS}=16V, T_J=125^{\circ}\text{C}$	-	-	10	
Gate to Source Leakage Current	$I_{GSS}$	$V_{GS}=\pm 12V, V_{DS}=0V$	-	-	$\pm 100$	nA
Drain to Source on Resistance	$R_{DS(on)}$	$V_{GS}=4.5V, I_D=3.5A$	-	36	45	m $\Omega$
		$V_{GS}=2.5V, I_D=2A$	-	43	60	
		$V_{GS}=1.8V, I_D=1A$	-	58	85	
Transconductance	$g_{fs}$	$V_{DS}=5V, I_D=3.5A$	-	5	-	S

**Dynamic Characteristics**

Input Capacitance	$C_{iss}$	$V_{GS}=0V, V_{DS}=10V, f=1\text{MHz}$	-	355	-	pF
Output Capacitance	$C_{oss}$		-	56	-	
Reverse Transfer Capacitance	$C_{rss}$		-	40	-	
Total Gate Charge	$Q_g$	$V_{DD}=10V, I_D=3.5A, V_{GS}=4.5V$	-	4.6	-	nC
Gate to Source Charge	$Q_{gs}$		-	0.66	-	
Gate to Drain (Miller) Charge	$Q_{gd}$		-	1.5	-	
Turn on Delay Time	$t_{d(on)}$	$V_{DD}=10V, I_D=1A, V_{GS}=4.5V, R_G=6\Omega,$	-	8	-	ns
Rise time	$t_r$		-	10	-	
Turn off Delay Time	$t_{d(off)}$		-	20	-	
Fall Time	$t_f$		-	15	-	

**Reverse Diode Characteristics**

Diode Forward Voltage	$V_{SD}$	$V_{GS}=0V, I_F=2A$	-		1.2	V
-----------------------	----------	---------------------	---	--	-----	---

Fig 1. Typical Output Characteristics

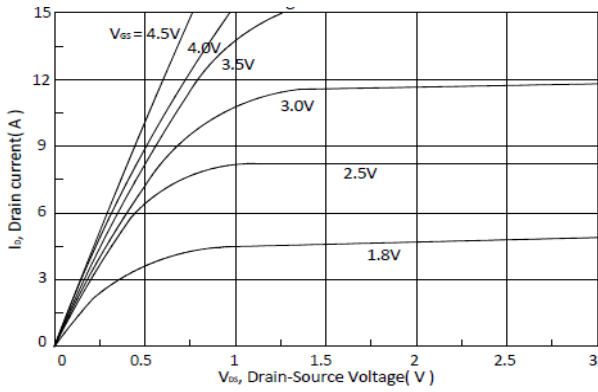

Figure 2. On-Resistance vs. Gate-Source Voltage

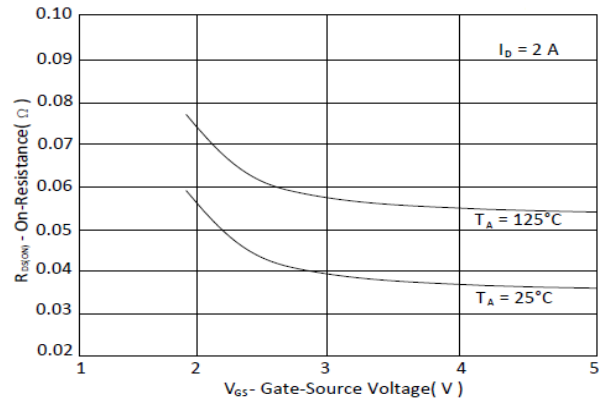

Figure 3. On-Resistance vs. Drain Current and Gate Voltage

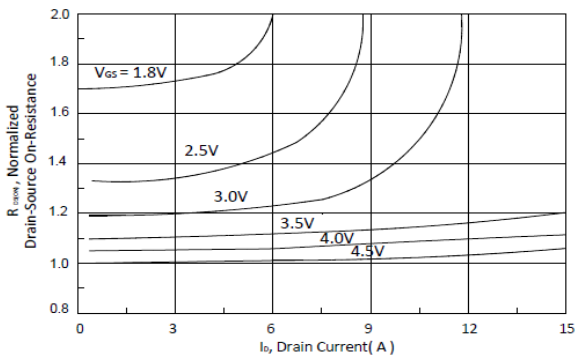

Figure 4. Normalized On-Resistance vs. Junction Temperature

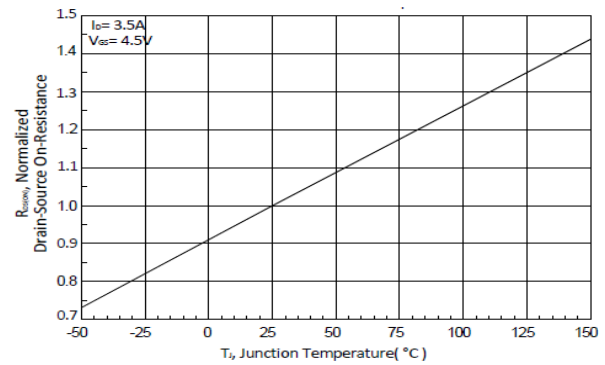

Figure 5. Typical Transfer Characteristics

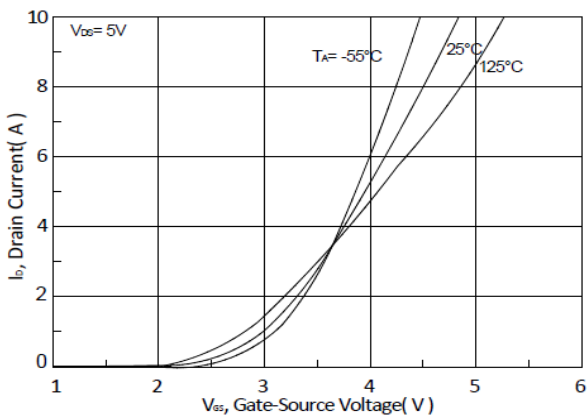

Figure 6. Typical Source-Drain Diode Forward Voltage

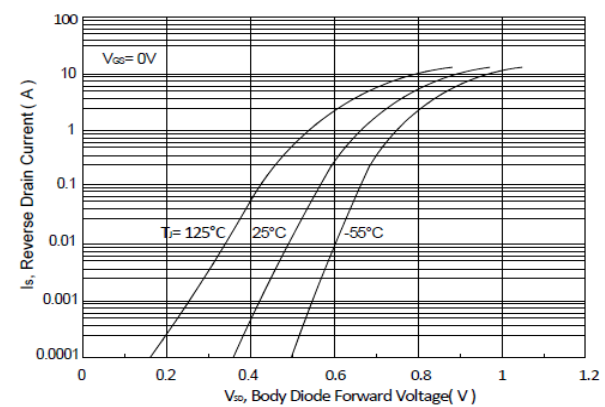

Figure 7. Typical Gate-Charge vs. Gate-to-Source Voltage

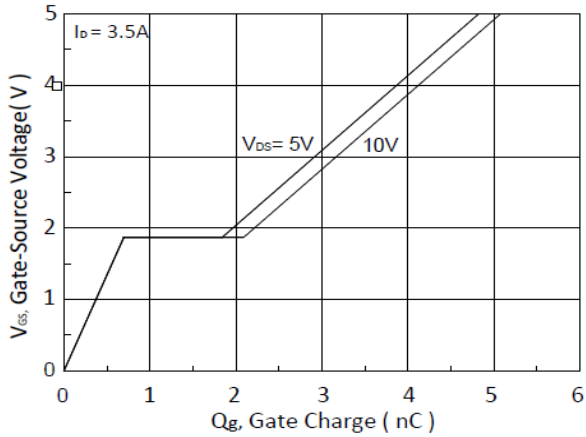

Figure 8. Typical Capacitance vs. Drain-to-Source Voltage

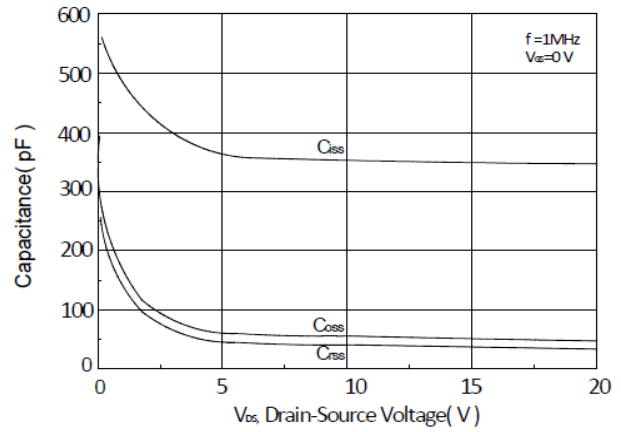

Figure 9. Maximum Safe Operating Area

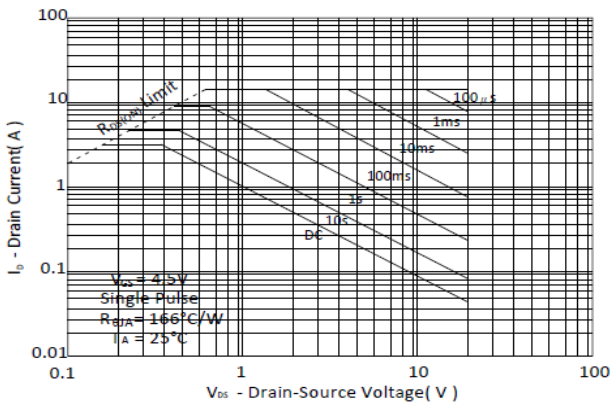

Figure 10. Maximum Drain Current vs. Case Temperature

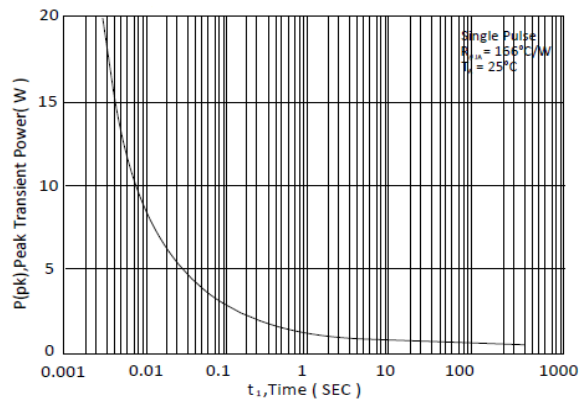
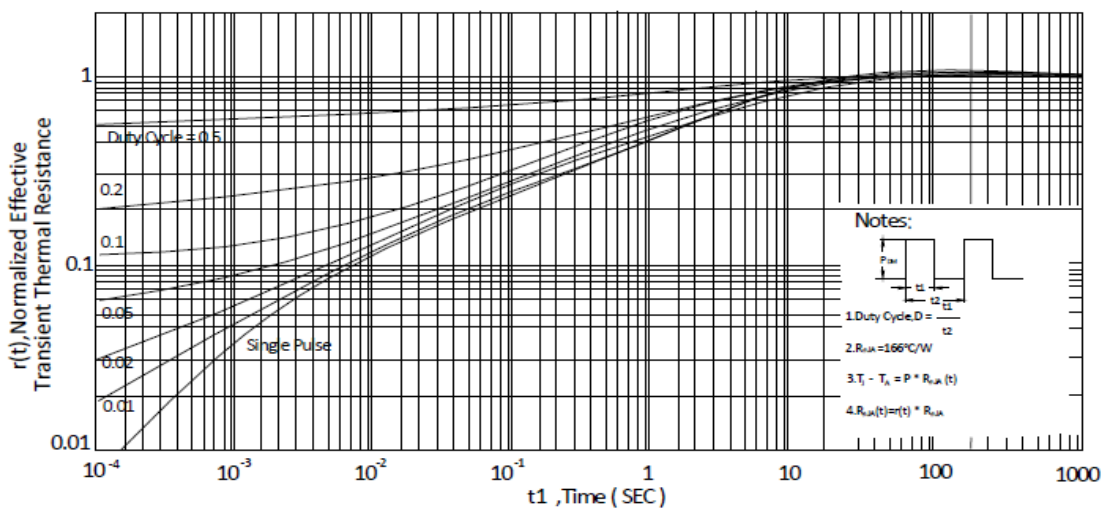
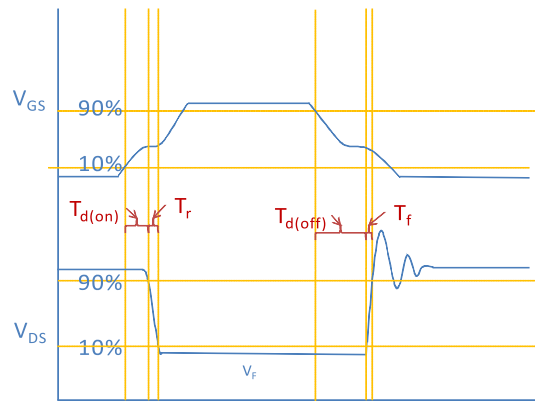

Figure 11. Normalized Maximum Transient Thermal Impedance, Junction-to-Ambient



## Inductive switching Test



## Gate Charge Test

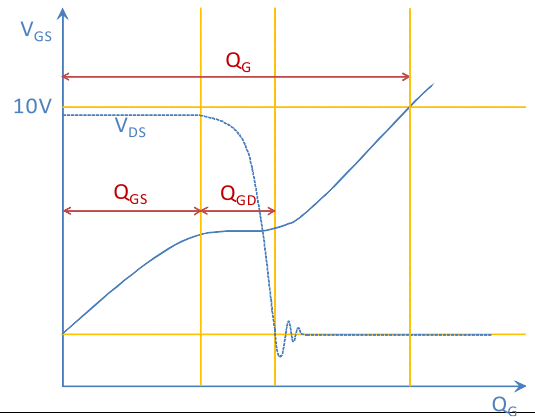

## Uclamped Inductive Switching (UIS) Test

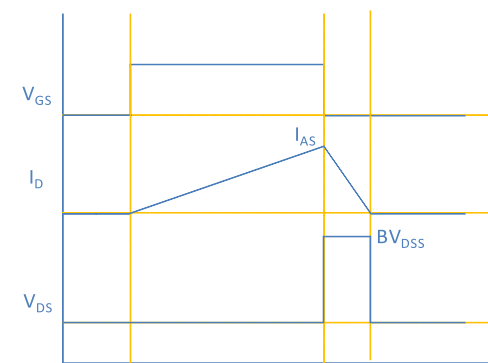
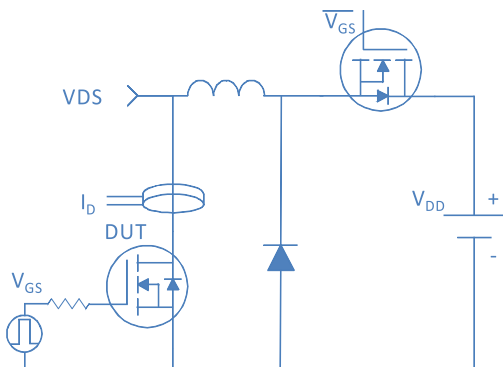

## Diode Recovery Test

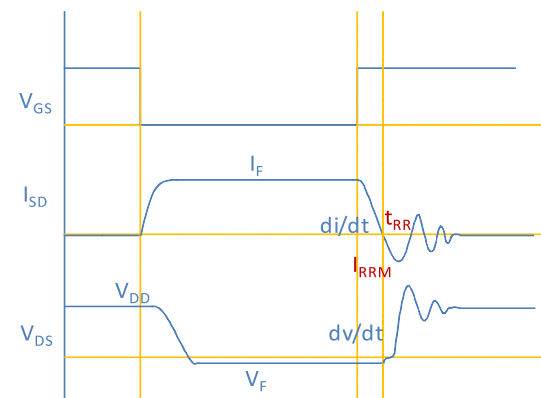

Package Outline

SOT-23, 3leads

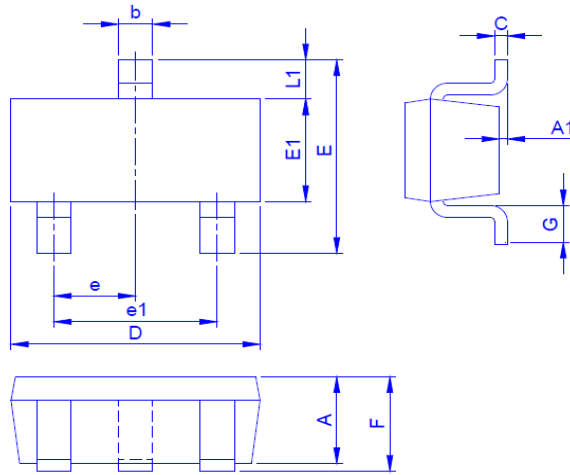

Dimension in mm

Dimension	A	A1	b	C	D	E	E1	e	e1	F	G	L1
Min.	0.70	0	0.3	0.08	2.80	2.25	1.2	0.90		0.80	0.3	0.50
Typ.					2.90			0.95	1.9			
Max.	1.15	0.1	0.5	0.20	3.02	3.00	1.7	1.00		1.25	0.6	0.75